

NATIONAL RADIO ASTRONOMY OBSERVATORY
Green Bank, West Virginia

ELECTRONICS DIVISION INTERNAL REPORT
NO. 301

**THE SINUOUS ANTENNA — A DUAL POLARIZED
ELEMENT FOR WIDEBAND PHASED ARRAY FEED
APPLICATION**

K. S. Saini
R. F. Bradley

February 13, 1996

The Sinuous Antenna — A dual polarized element for wideband phased array feed application

Kamaljeet Singh Saini Richard F. Bradley

February 13, 1996

1 Introduction

Typical radioastronomy applications require wideband antenna elements to provide large observable radio spectrum without the need to change feeds. Polarization measurements require the antenna to possess the capability of distinguishing between two orthogonal senses of polarization (preferably linear.) in the received signal. Some other conventional applications, like the direction finding systems, require similar antennas. The sinuous¹ antenna element described here is one such element, suited to these kinds of applications. It is compact, has a good E- and H- plane radiation pattern congruence, and possesses an input impedance which is essentially independent of frequency. Also, its phase center shows little variation over the designed band of operation. Few other candidate elements possess all these properties satisfying the requirements for similar and related applications.

As will be described later, the circumferential nature of current distribution, arising out of the physical geometrical shape of the element, ensures a good E- and H- plane pattern uniformity, while the self complimentary two-dimensional structure guarantees a frequency independent input impedance. This is important in achieving an efficient power transfer to free space over the entire band of operation.

The sinuous element described here was designed for the 1.0GHz - 2.5GHz frequency band. Simulated and experimental results of the antenna performance are presented.

¹First conceived by R. H. Du Hamel, "Dual Polarized Sinuous Antennas." European Patent Application 019 8578, filed Feb. 19, 1986. (U.S. Patent 703,042, Feb. 19, 1985.)

2 Conditions for frequency independent radiation characteristics of an antenna element

The properties of any radiating element are a function of the element size, evaluated in terms of the wavelength at the operating frequency. If an antenna is constructed in such a way that any arbitrary scaling of its physical structure yields the original structure (or a rotated version of it), then its properties would be independent of frequency, since the antenna dimensions (in wavelengths) would be identical at all frequencies. An antenna constructed to satisfy the condition of independence from scaling as described above, would be defined entirely by angles.

2.1 The log periodic concept

Consider an antenna which transforms to itself (or to a rotated version of itself,) only when scaled by a fixed factor τ . Under such circumstances, the frequency performance should be expected to be identical at frequency, f and at frequency, τf for reasons same as before. In particular, the properties would be expected to be periodic in frequency with a period of $\log \tau$. Hence the name *log periodic*. By keeping the value of the scale factor τ close to unity, the periodic variations in the performance can be kept within desired limits.

The requirement that a structure transform to itself when scaled, implies that it extends from zero to infinity, and is of little importance from the point of view of practical applications. However, a good frequency independent performance (albeit only in the frequency band of design) can be obtained by truncating and using only that portion of the log periodic structure, that lies between two spheres of radii, r_1 and r_2 . The radii are determined from the considerations of the upper and the lower frequency cutoff desired for the operational frequency band. The active resonant region then lies somewhere within the two extremities of this truncated section so long as the operating frequency is within the design band. This truncated structure yields an in band performance comparable to the infinite structure, provided the currents are sufficiently attenuated near its ends due to efficient radiation from the interior of the structure. This truncated structure then is of great practical importance.

2.2 Requirements for the frequency independence of the input impedance of a structure

Frequency independence of the input impedance is highly desirable property of any antenna element, because it makes it easier to efficiently couple the RF energy to the radiating element at all frequencies, without the need to resort to frequency dependent impedance transforming networks. It was shown by Booker², that any antenna element that is self complimentary has an input

²H. G. Booker: "Slot Aerials and Their Relation to Complimentary Wire Aerials (Babinet's Principle)." J.IEE(London), pt.IIIA, pp.620-627, 1946.

impedance, which is not a function of frequency. A self complimentary structure does not guarantee a frequency independent radiation pattern, but if a log periodic antenna is constructed to be self complimentary, then the element will exhibit a periodic variation in the radiation characteristics, while having a constant input impedance. As stated earlier, the periodic variation of the radiation characteristics could be made small by assigning to τ (the log periodic scale factor,) a value close to unity. Such a structure would have a frequency independent radiation pattern and input impedance. This is the underlying design philosophy followed to design the sinuous element.

3 Design, fabrication and assembly of the sinuous antenna

The requirement of dual polarization dictates the need to have two equivalent structures, each catering to one sense of polarization. This is done by first generating one set of “arms” to achieve a linear polarization, and then adding another set of arms, similar to the first one, but rotated through 90° , to provide the orthogonal polarization sense. It has to be ensured that the two sets of “arms” do not intersect each other, and the geometry of the structure conforms to the log periodic principles, and is self complimentary as well. We began by tracing out the sinuous curve.

3.1 Generating the sinuous curve

The log periodic structure is considered to be composed of “cells”, with each cell being a scaled version of its predecessor. The “cells” of the sinuous structure were generated from the sinuous curve, which is defined by the equation provided by R. H. Du Hamel et. al.³

$$\phi = (-1)^p \alpha_p \sin \frac{180 \ln(r/R_p)}{\ln(\tau_p)} \quad (1)$$

where, r , ϕ are the polar coordinates of the curve, for the p -th cell. Cell-1 corresponds to the outermost cell, with radius R_1 . Therefore, $R_{p+1} \leq r \leq R_p$. In general, $R_p = \tau_{p-1} R_{p-1}$. To adhere to the log periodic design philosophy, α_p and τ_p are constants. The sinuous curve obtained from this equation formed the basis for creating the sinuous “arm”(see figure 1a) as described below.

3.2 Creating the sinuous pattern

The sinuous curve obtained above was swept through an angle $\pm \delta$ about its axis to generate one sinuous arm(see figure 1b.) This arm was then copied after

³The design equations of the sinuous antenna are laid out in detail in the Antenna Engineering Handbook (III Ed.), Chapter 14, Frequency Independent Antennas by R. H. Du Hamel and J. P. Scherer, edited by Richard C. Johnson, Mc Graw Hill Publishers.

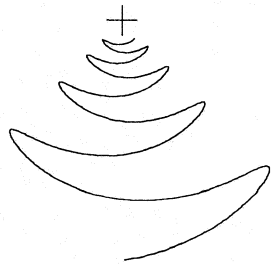

SINUOUS CURVE

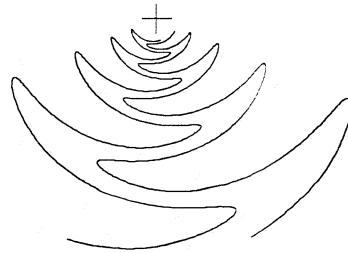

ONE "ARM" FORMED BY SWEEPING
THE SINUOUS CURVE THROUGH $\pm 22.5^\circ$

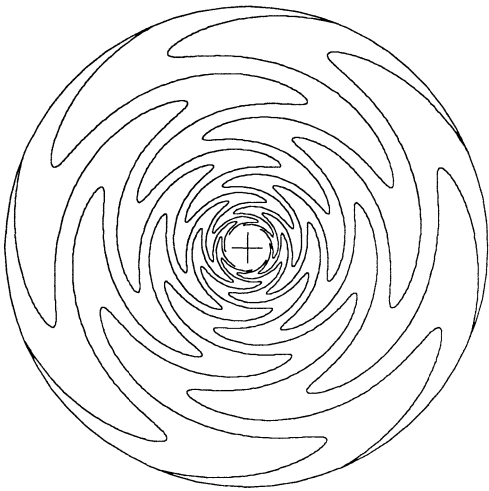

COMPLETED FOUR ARM PATTERN

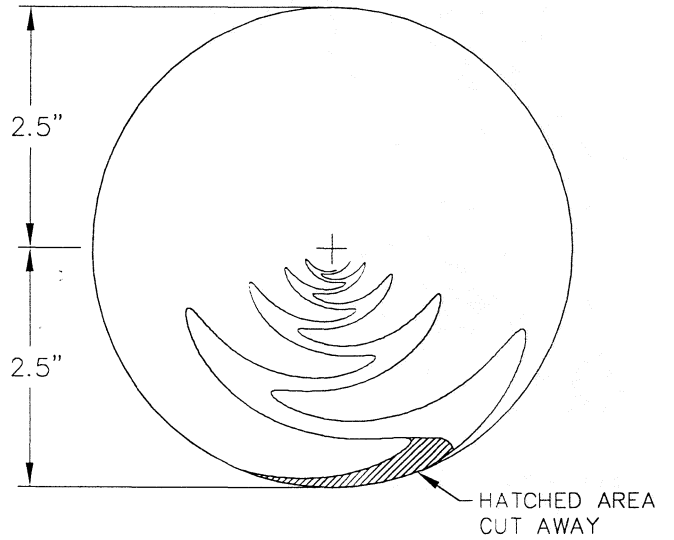

FINAL ANTENNA REALIZATION PATTERN

Figure-1

rotation through 180° about the origin. This created one dipole. This structure was now copied after rotation through 90° about the origin, to get the desired dual dipole (and hence dual polarization) sinuous antenna.

This procedure was executed with the aid of Autocad. An Autolisp program (Appendix A) was written to compute and draw the sinuous curve based on the above equations and rules, given the design parameters: τ , R_1 and the inner pattern radius. The basic curve, thus obtained, was subsequently manipulated as already described to create the required artwork for printed circuit board (PCB) fabrication (see figure 1c & d.)

3.3 The self complimentary sinuous pattern and calculation of the input impedance

A sinuous structure was generated as outlined above with the following design parameters: $\alpha = 45^\circ$, $R_1 = 2.5 \text{ inches}$ and $\tau = 0.75$. A self complimentary structure was ensured by setting $\delta = 22.5^\circ$. Figure 1c & d show the completed pattern with these design parameters. Notice that the actual artwork generated has the "stubs" occurring at the outer periphery (corresponding to the next larger cell of the sinuous pattern,) trimmed off. This was done because these appendages, being of a resonant wavelength at about 1.5GHz, disturbed the radiation from the actual resonant cell at this frequency, and caused a distortion in the beam pattern shape.

As shown by Booker, an N-arm, self complimentary structure has a balanced input impedance of each arm pair given by:

$$Z_m = \frac{60\pi}{\sin \frac{M\pi}{N}} \Omega \quad (2)$$

where M is the mode number. When fed in mode-1, a four arm structure will therefore present an input impedance of 267Ω . The actual impedance is somewhat lower owing to the feed structure at the center.

3.4 Construction and assembly

The sinuous element, as defined by the artwork, was fabricated on a 10mil thick polyester substrate. A small hole was cut out at the center, to pass the antenna feed terminals to the balun behind. This antenna PCB disc was next attached to a 1" thick styrofoam disc of equal diameter. The styrofoam disc had a threaded teflon insert attached into the other face to hold the hollow cylindrical G-10 glass epoxy rod. The balun passed through the support rod and styrofoam disc, and through the hole in the center of the antenna PCB, connected to the feed terminals. The whole assembly was itself fixed to a reflecting backplane by the support rod with the aid of a mounting ring assembly.

3.5 Frequency coverage

For a sinuous structure, the active resonant region lies at a radius given by:

$$r = \frac{\lambda}{4(\alpha + \delta)} \quad (3)$$

where, α and δ are in radians. The resonant radii at various frequencies for the chosen design parameters are tabulated below, based on the above relation.

<i>Freq.(GHz)</i>	<i>ResonantRadius(inch)</i>
1.0	2.5
1.2	2.1
1.4	1.8
1.6	1.6
1.8	1.4
2.0	1.2
2.5	1.1

Thus the 5 inch diameter element designed above, covers the entire 1.0GHz - 2.5GHz band as desired.

4 The feed structure

To match the 50Ω unbalanced source to the balanced impedance presented by the element, a “tapered stripline” balun was used. A Klopfenstein⁴ impedance taper profile was used, and the ground plane was tapered simultaneously to provide the required transition from a balanced line to an unbalanced line. The balun used was designed to transform a 140Ω balanced impedance to a 50Ω unbalanced impedance. The use of a 140Ω balun with an antenna that presents about 240Ω impedance, was resulted in some impedance mismatch. and an expected standing wave ratio(SWR) of about 1.7 .

4.1 Balun design

The Klopfenstein impedance taper is defined by:

$$\ln Z(z) = \frac{1}{2} \ln(Z_o Z_L) + \frac{\Gamma_o}{\cosh A} A^2 \phi(2z/L - 1, A) \quad (4)$$

where $0 \leq z \leq L$ and $\Gamma_m = \Gamma_o / \cosh A$. Γ_m being the maximum permissible reflection coefficient in the passband of the taper, and $\Gamma_o = \frac{Z_L - Z_o}{Z_L + Z_o}$. The modified Bessel function $\phi(x, A)$ was computed using the technique provided by Grossberg⁵. The required impedance profile to match 140Ω to 50Ω was

⁴R. W. Klopfenstein, “A Transmission Line Taper of Improved Design,” Proc. IRE. Vol.44, pp.31-15, January 1956.

⁵M. A. Grossberg, “Extremely Rapid computation of the Klopfenstein Impedance Taper”, Proc. IEEE, Vol.56, pp.1629-1630, September 1968.

subsequently computed. The trackwidth profile was subsequently computed numerically, using the HP-High Frequency Structure Simulator (HFSS) software for a 62mil FR-4 Glass Epoxy substrate, $\epsilon_r = 4.8$ (Appendix B.)

The balun was fabricated after preparing an artwork based on the the above calculations. An SMA connector soldered to the 50 Ω end, formed the test and measurement port.

Subsequently, a better match was obtained by redesigning the balun on similar lines for 240 Ω impedance using a 125mil FR-4 Glass Epoxy substrate, $\epsilon_r = 4.8$ (Appendix B.) This balun was not available at the time of the experiment, and so all the subsequent antenna measurements were made using the 140 Ω balun constructed as described above.

4.2 Balun performance

To check the performance of the balun, the balanced end was terminated with a 140 Ω chip resistor, and return loss was measured at the 50 Ω port, using a vector network analyzer. The return loss was found to be better than -20dB in 1.0GHz to 2.0GHz frequency band.

The modified balun had a return loss of better than -18dB in the same frequency range, when terminated with a 240 Ω resistive network.

5 Element performance

This section presents the simulated as well as experimental performance results of one sinuous antenna element mounted in front of a reflecting backplane(to get a unidirectional beam), and fed by a tapered stripline balun as constructed above.

5.1 HFSS simulation

The antenna element consisting of the sinuous structure and the tapered balun were entered into the HFSS⁶ to get an estimate of the expected radiation pattern. Owing to computing constraints, the structure consisted of only one pair of arms corresponding to one sense of polarization, instead of the usual two. This deprived the property of self complimentary symmetry from the structure and could lead to a non constant value for the input impedance. and some variation of beam shape in the simulated results. The sinuous pattern was modeled using 100mil long line segments, instead of the finer resolution used in generating the artwork for actual PCB fabrication, to reduce the mesh complexity. The “arms” were fed by equally excited coaxial lines, whose lengths were different by 180° at 1.0GHz, to simulate balanced excitation of the antenna structure. The radiation pattern plot at 1.0GHz is shown in figure 2. The 3dB beamwidth turns out to be about 80°.

⁶HP’s High Frequency Structure Simulator, Release 3.10 was used to carry out the simulations.

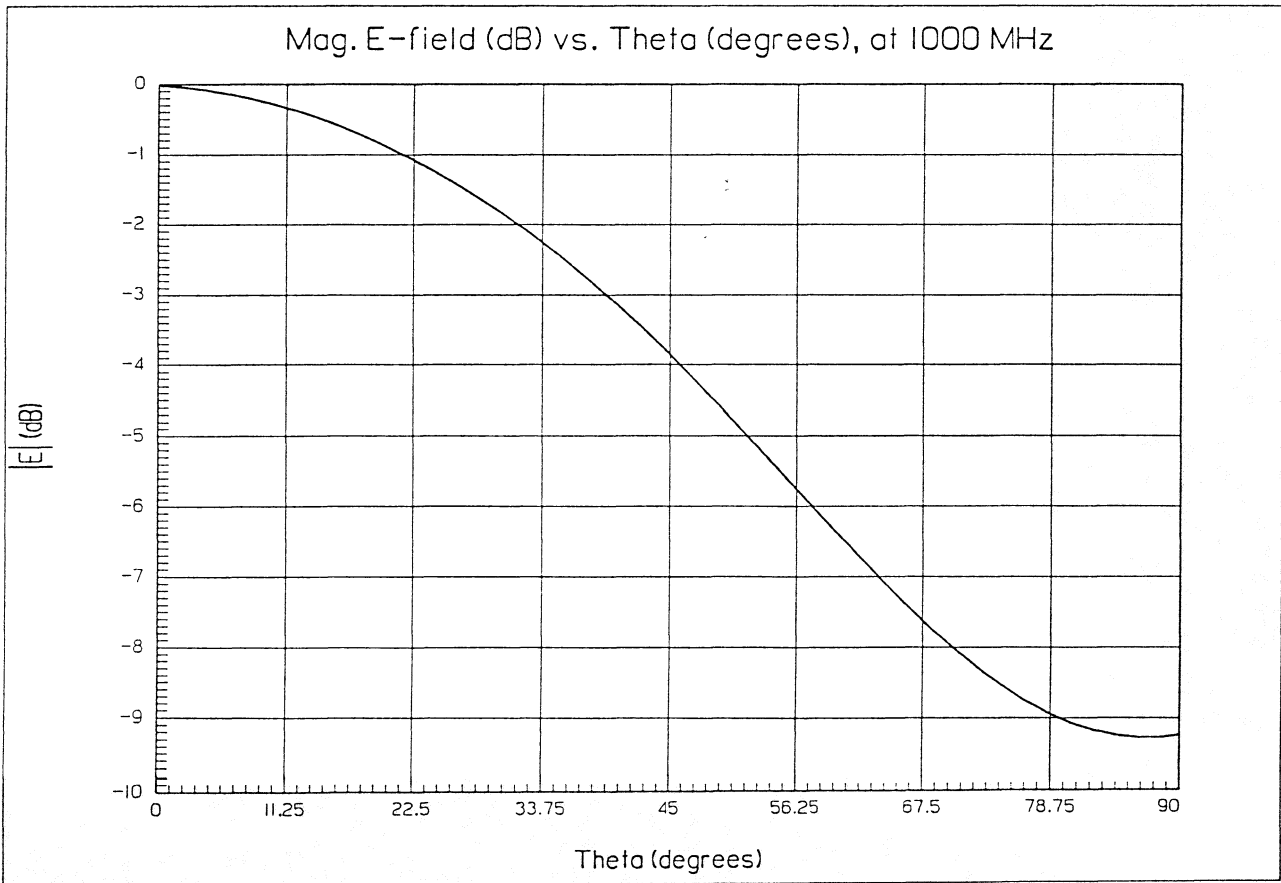
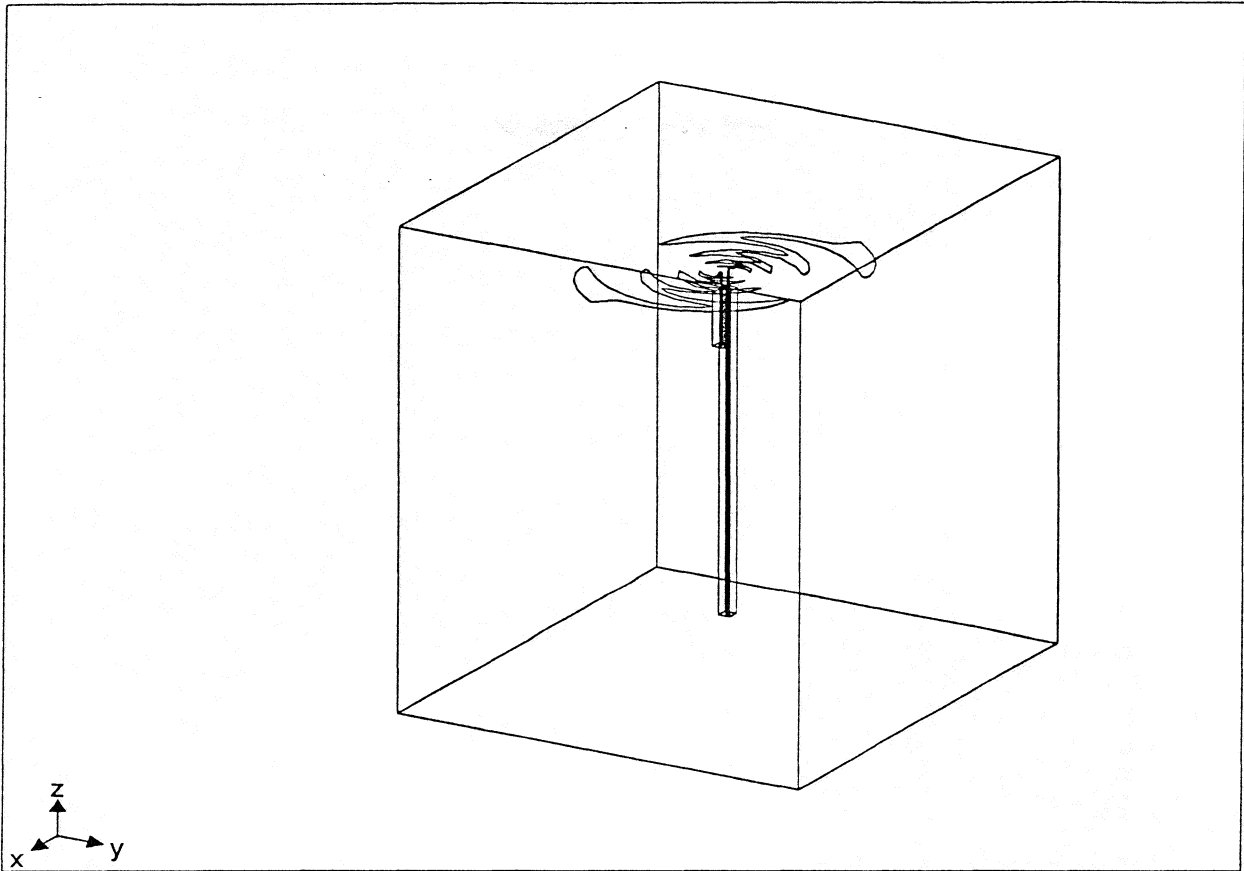

FIGURE 2

5.2 Experimental results

5.2.1 Radiation pattern

Measurements were carried out by using the sinuous test antenna as the receive element on the test range⁷. The transmit antenna was an L-band horn (design band of 1.3GHz - 1.7GHz), fed by a CW carrier from a signal generator. The received signal from the test antenna was compared against a sample of the transmitted signal using a phase-amplitude measurement system. The receive antenna was rotated in azimuth, and the received signal strength was recorded as a function of the azimuthal position to yield the required radiation pattern for the test antenna. Care was taken to ensure that the axis of rotation of the test antenna coincided with its phase center, to avoid filling up nulls in the beam pattern, if any. This adjustment required the test antenna to be moved along the radial axis towards (or away from) the transmitting horn, till the phase variation was contained within $\pm 4^\circ$ for azimuthal positions ranging from -45° to $+45^\circ$. Measurements were made by rotating the test antenna both in its E-plane and H-plane, at 1.0, 1.2, 1.4, 1.6, 1.8 and 2.0GHz. The 3dB beamwidth was 80° , in close agreement with the predicted value. (See figure 3.)

5.2.2 Polarization wobble and cross-polarization rejection

The polarization wobble was measured by turning the polarization of the transmit horn, and locating its orientation for the sharply defined minima in the received signal strength as a function of frequency in the 1.0GHz - 2GHz band. The polarization wobble was $\pm 5^\circ$ in this frequency range. The cross-polarization rejection was better than -25dB throughout the band. (See figure 4.)

5.2.3 SWR measurements

SWR measurements were made using a vector network analyzer, connected at the input of the balun, in a single port configuration. The measured SWR was about 1.5 without the metallic backplane, and in the range of 1.8 - 2.0 with it — close to the theoretically expected value of 1.7 for the balun used. The placement of the backplane introduced a reactive component in the input impedance. (See figure 5.)

6 Conclusion

Antennas are impedance matching devices, that transform the impedance of the RF source to that of free space. To be useful, they should be capable of achieving this transformation over the entire band of operation (frequency independent input impedance.) A high bandwidth system therefore requires a wideband antenna. Additionally, the radiation pattern should be same at

⁷Measurements were carried out at the antenna test facility of the National Radio Astronomy Observatory, Green Bank, West Virginia.

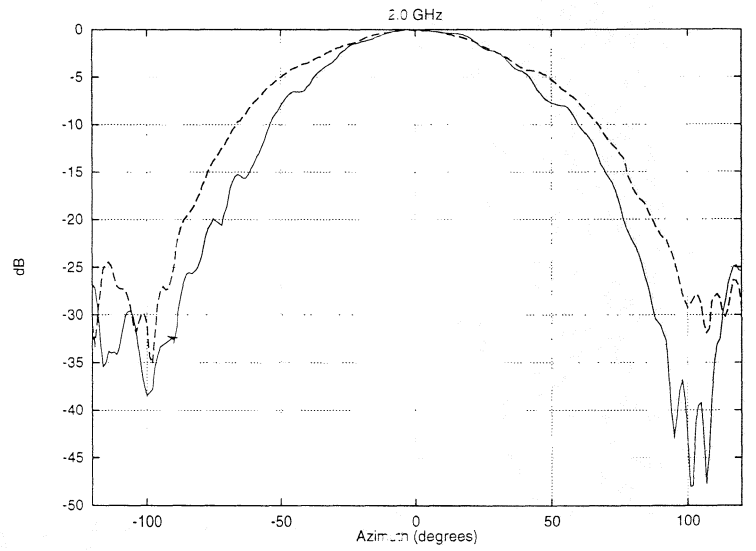
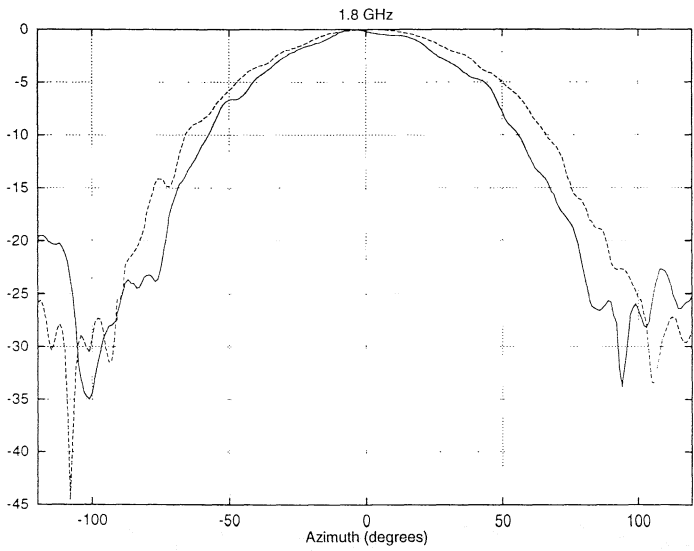
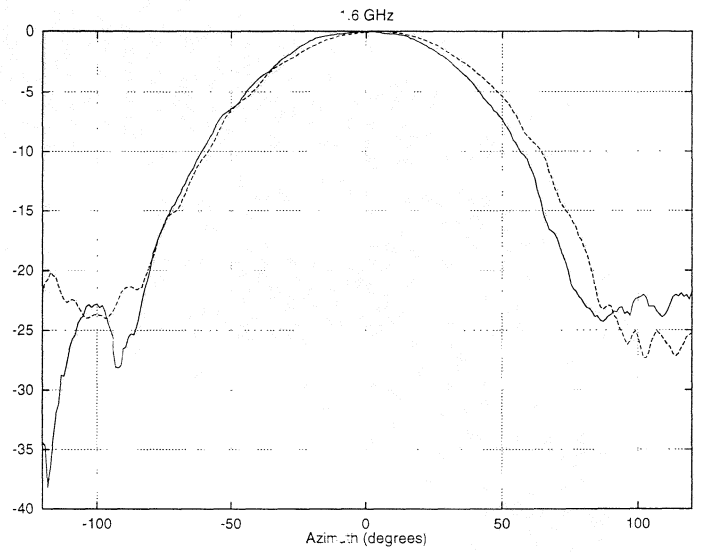
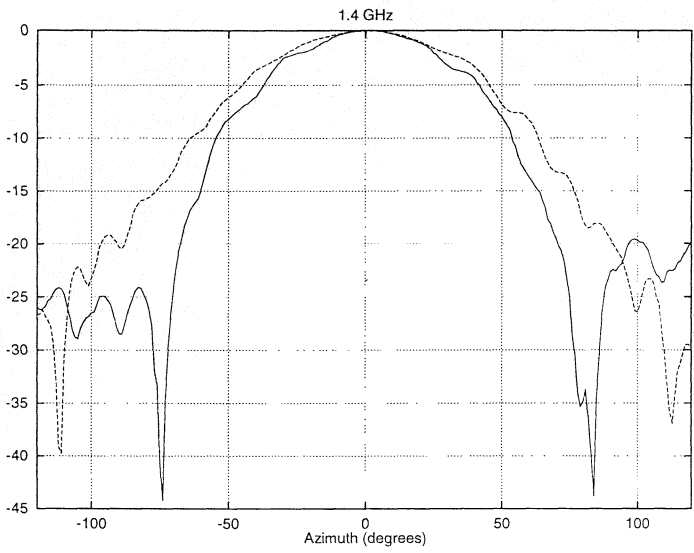
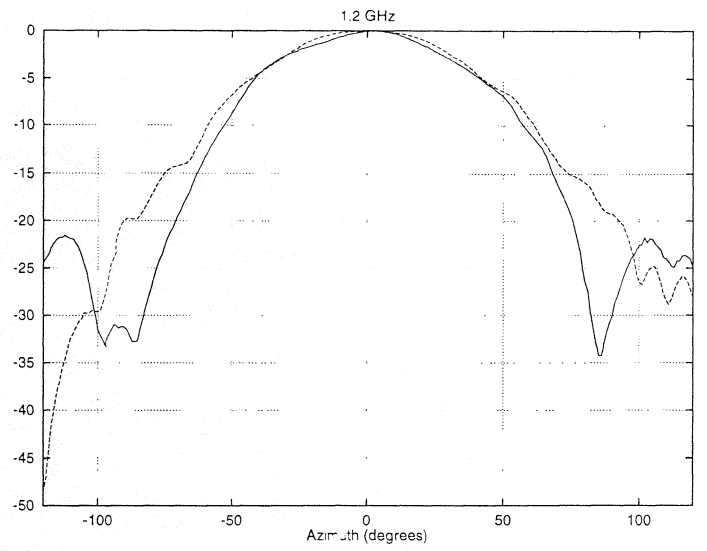
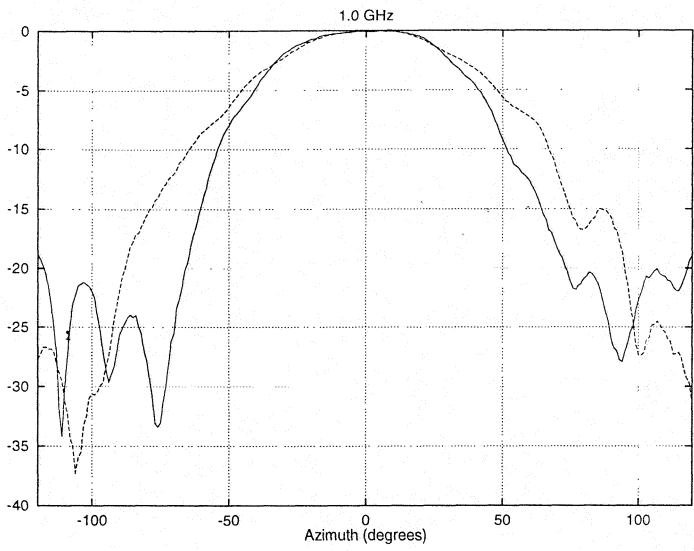

Figure-3

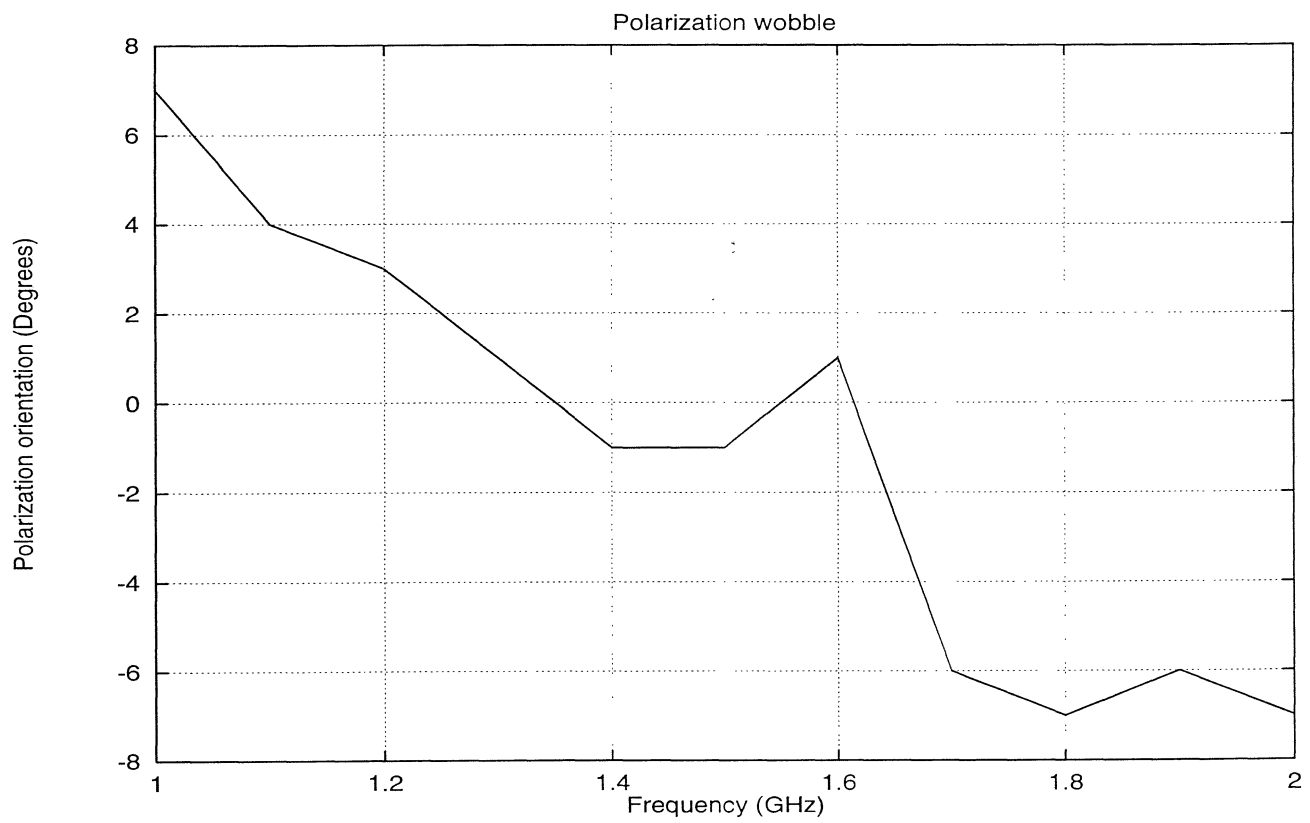
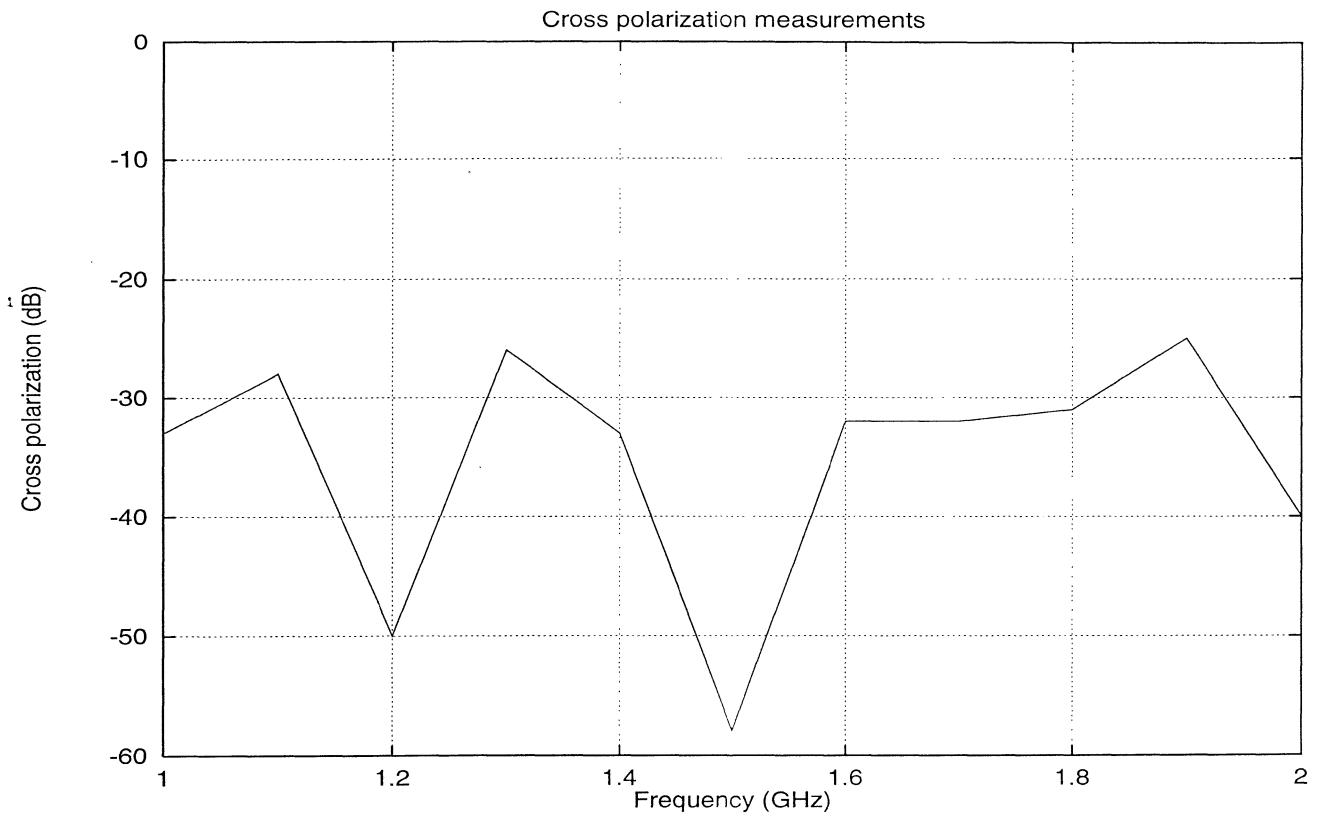

Figure-4

MARKER 1
 1.2 GHz
 -14.137 dB

 MARKER 2
 1.4 GHz
 -13.536 dB

 MARKER 3
 1.6 GHz
 -13.943 dB

 MARKER 4
 1.8 GHz
 -21.444 dB

24 DEC 95
 02:33:43

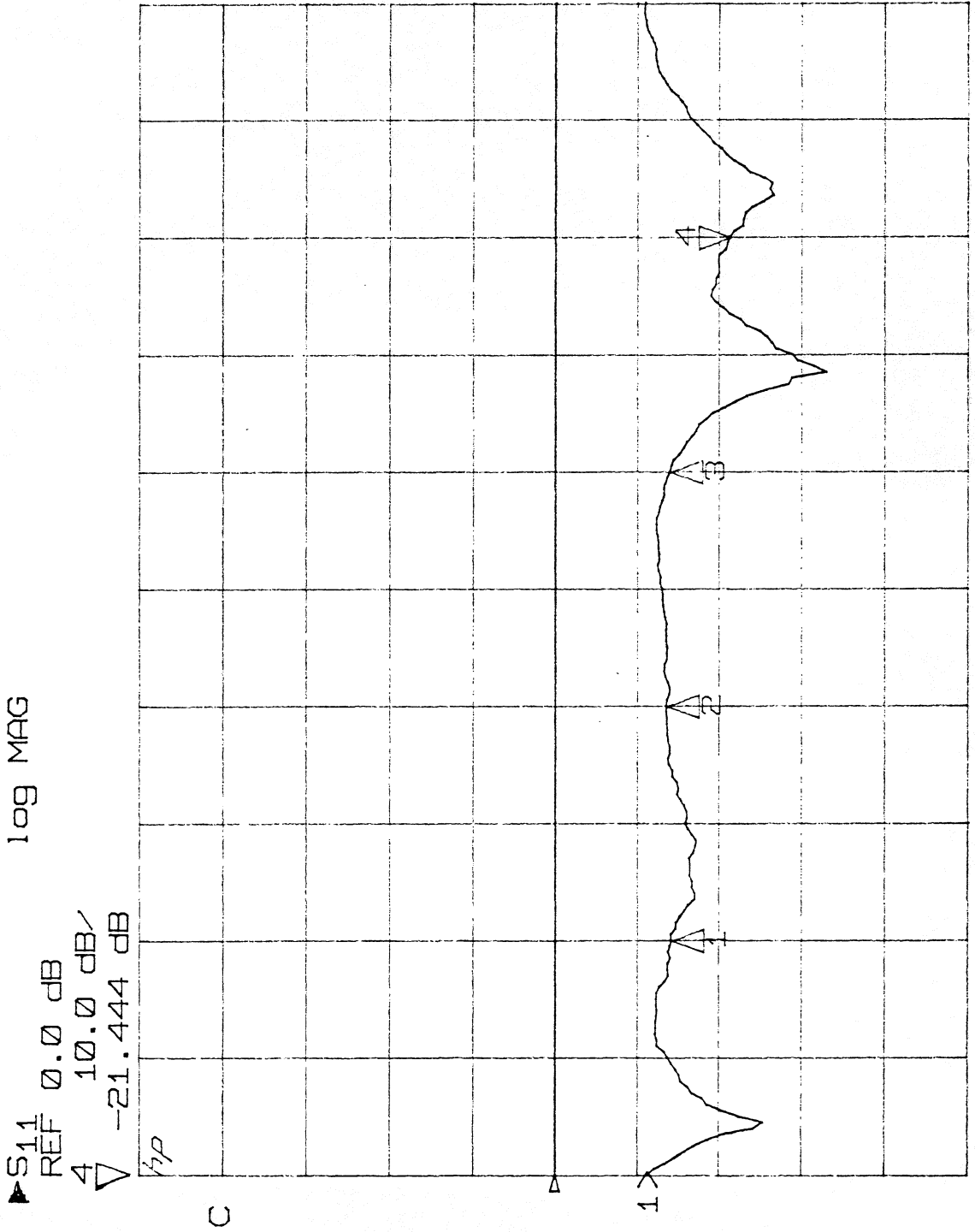

START 1.000000000 GHz
 STOP 2.000000000 GHz

FIGURE 5

all frequencies in the operation band. Further, some applications require the antenna to be polarized, while some require that the physical structure be as small as possible. The ease of fabrication of the structure, should be viewed as an added advantage.

The sinuous antenna described above. has all these qualities, and should be particularly useful for phased focal plane array applications.

7 Acknowledgements

We would like to thank Dr.J. R. Fisher who made many suggestions to improve the performance of the antenna. Most of his suggestions were incorporated into our final design.

We also acknowledge the contributions of Donald G. Stone who prepared Autocad drawings and artworks for our designs, of Richard Hall and Danny E. Boyd who helped us in assembly and testing of the numerous prototypes of our antenna elements, and of Garnet Taylor who fabricated most of the structural components for the assembly and mounting arrangement of the antenna.

Appendix: A

- Listing of the Autolisp routine.

```

;;
;;
;;Autolisp routine to generate the basic sinuous curve, given the
;;parameters:
;;minimum radius -> radius of the inner circle that truncates the
;;infinite pattern at the high frequency end.
;;maximum radius -> radius of the outer circle that truncates the
;;infinite pattern at the low frequency end.
;;tau -> the log periodic cell scale factor.
;;incremental step -> the lengths of straight line segments used
;;to implement the curve.
;;
;;Donald G. Stone
;;

```

```

(defun curve ()
  (prompt "Routine to draw the basic sinuous curve  ") (terpri)
  (setq start (getpoint "Pick the start point  ")) (terpri)
  (setq r1 (getreal "Enter the minimum radius  ")) (terpri)
  (setq r2 (getreal "Enter the maximum radius  ")) (terpri)
  (setq s (getreal "Enter the incremental step  ")) (terpri)
  (setq tau (getreal "Enter the value of tau  ")) (terpri)
  (while (< r1 (- r2 s))
    (setq f1 (* (/ pi 4) (sin (* pi (/ (log (/ r1 r2)) (log tau)))))))
    (setq x1 (+ (* r1 (cos f1)) (car start)))
    (setq y1 (+ (* r1 (sin f1)) (cadr start)))
    (setq r1 (+ r1 s))
    (setq f2 (* (/ pi 4) (sin (* pi (/ (log (/ r1 r2)) (log tau)))))))
    (setq x2 (+ (* r1 (cos f2)) (car start)))
    (setq y2 (+ (* r1 (sin f2)) (cadr start)))
    (command "line"
      (setq p (list x1 y1))
      (setq p (list x2 y2))
      ""
    )
  )
)
)

```

Appendix: B

- Mechanical details of the 50 Ω - 140 Ω balun (Version 2.)

(The drawing shows two baluns drawn back to back.
This was done for the convenience of fabrication.)

- Mechanical details of the 50 Ω - 240 Ω balun (Version 4.)
 - Performance plot of the 50 Ω - 240 Ω balun.

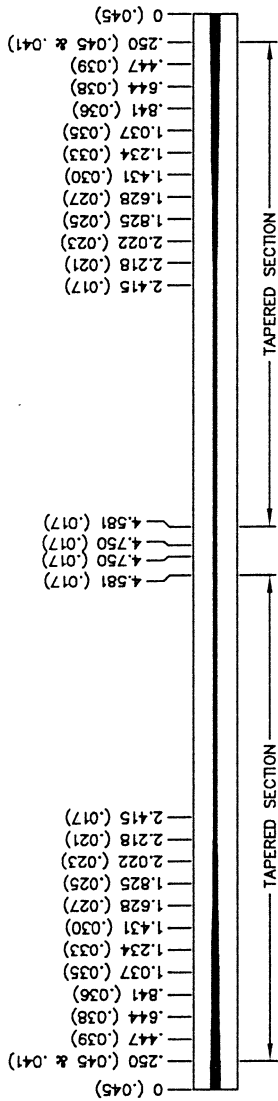

PC BOARD TOP

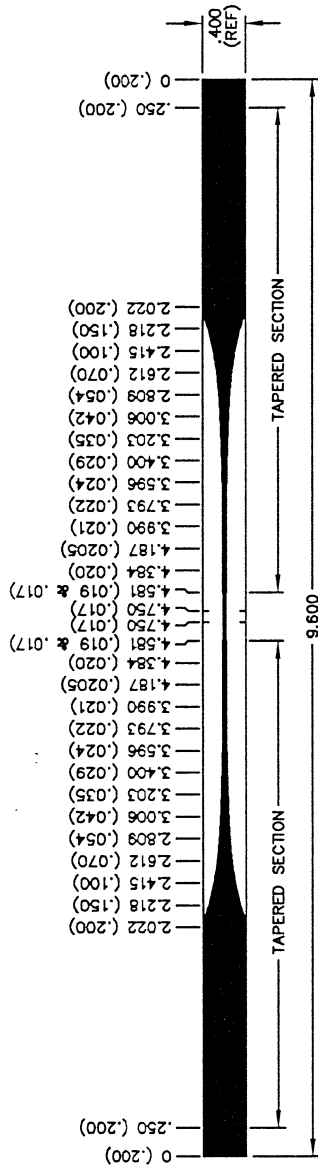

PC BOARD BOTTOM

NATIONAL RADIO ASTRONOMY OBSERVATORY		CHARLOTTESVILLE, VA. 22903	
TITLE DIMENSIONAL DATA			
PROJECT TAPERED BALUN PCB - VERSION 2			
PROJECT SINUOUS APERTURE ANTENNA			
DESIGN R.	BRADLEY	3-28-94	COMPUTER DRAWING
DRAWN	DGS	3-12-94	MATERIAL
SHEET	1 OF 1		FINISH
SCALE	FULL		DWG. NO. B10001R002
			REVISION

NOTES

- △ DIMENSIONS IN PARENTHESIS "0" ARE FROM THE CENTERLINE OF THE ARTWORK.
- △ EACH HALF OF THE VERTICAL DIMENSIONS ORIGINATE FROM THEIR RESPECTIVE OUTSIDE END.
- △ THE AUTOCAD SPLINETYPE USED TO GENERATE THE CURVE IS CALLED "QUADRATIC B-SPLINE".

REV	DATE	BY	DESCRIPTION	CHANGE ORDER
A	11-17-95	DGS	NOTCHES ADDED TO .400 END	---

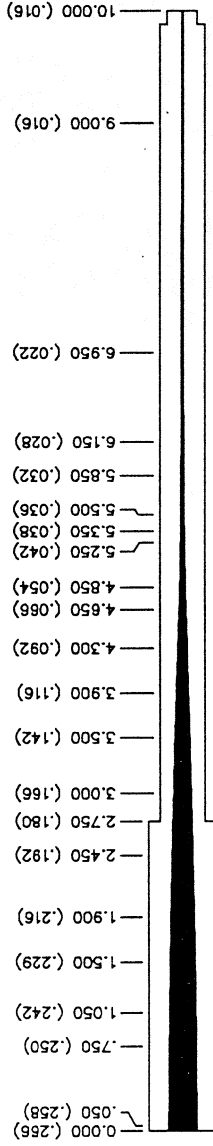

PC BOARD TOP

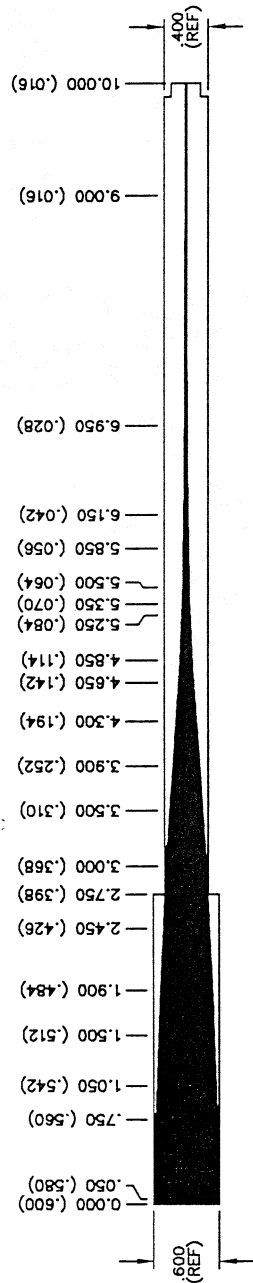

PB BOARD BOTTOM

NATIONAL RADIO ASTRONOMY OBSERVATORY	
CHARLOTTESVILLE, VA. 22903	
TITLE: DIMENSIONAL DATA	
PROJECT: TAPERED BALUN PCB - VERSION 4	
DESIGN: SANNI	COMPUTER DRAWING: B-23-95
DRAWN: DGS	MATERIAL: B-28-95
SHEET: 1 OF 1	FINISH:
SCALE: FULL	DWG. NO.: B10001R015
	REVISION: A

NOTES

- △ DIMENSIONS SHOWN IN PARENTHESIS "()" ARE TRACE WIDTHS AT THE DIMENSIONAL LOCATION GIVEN.
- △ THE AUTOCAD SPLINETYPE USED TO GENERATE THE CURVE IS CALLED "QUADRATIC B-SPLINE".

log MAG

▶ S11
REF 0.0 dB
4 10.0 dB
▽ -18.102 dB

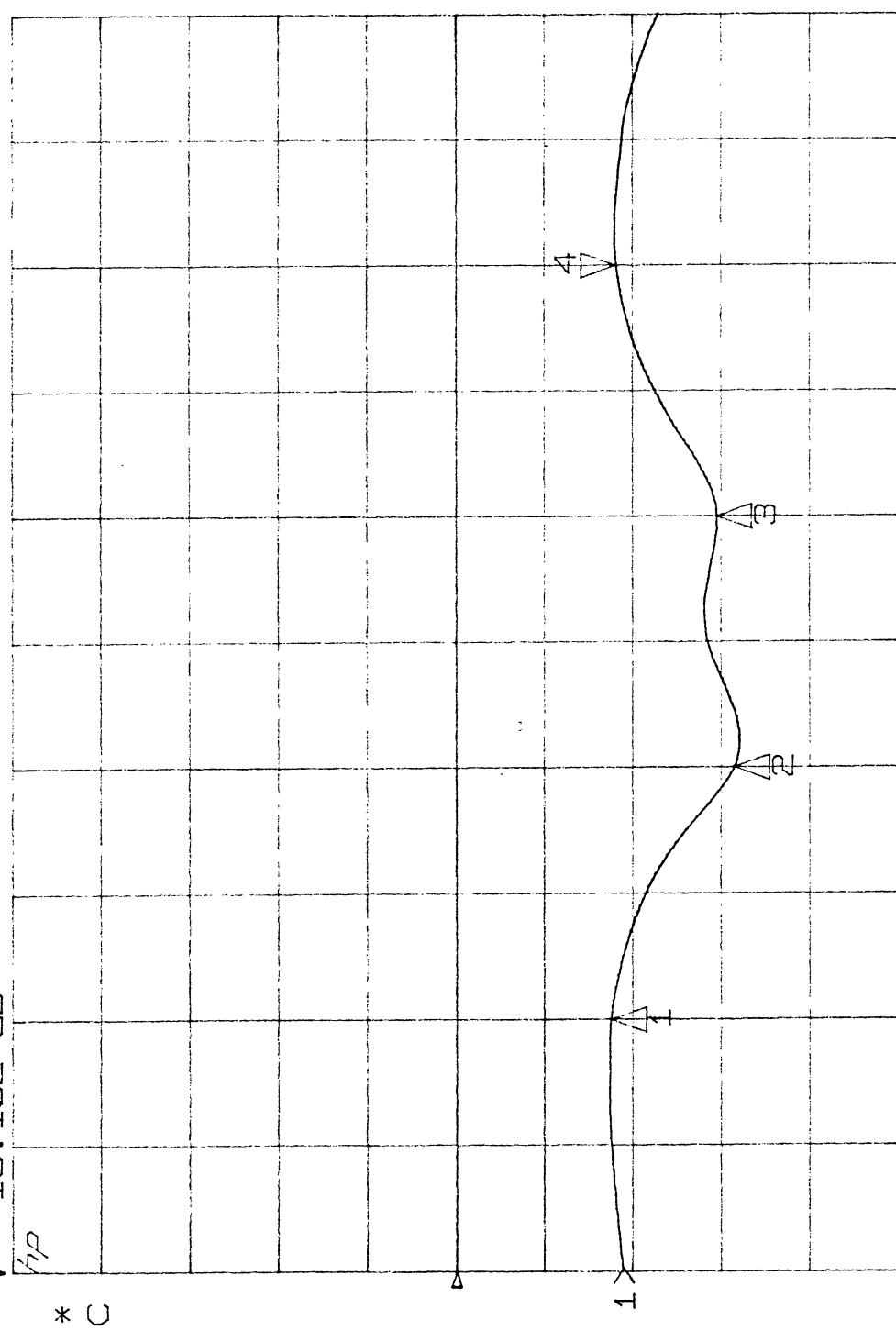

MARKER 1
1.2 GHz
-17.539 dB

MARKER 2
1.4 GHz
-31.485 dB

MARKER 3
1.6 GHz
-29.464 dB

▶ MARKER 4
1.8 GHz
-18.102 dB

50-240 Ω BALUN

START 1.000000000 GHz
STOP 2.000000000 GHz

24 DEC 95
01:33:14